

RP0603ZZ-XXXXWN-2Q Features:

- Wraparound Terminals
- Solder or Epoxy Attachment
- Customer Defined Testing Available
- RoHS Compliant or SnPb Available
- Tape & Reel or Waffle Pack Available (Standard is bulk)

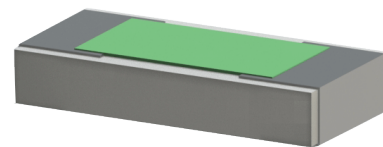

RP0603ZZ-XXXXWN-2Q Parameters:

Resistance Range: 10Ω - 1KΩ
 Rated Power: 2.4W*
 Construction: Thick Film on AIN
 Operating Temperature: -55 to +150°C

■ Actual Size

* Rating based on ≤100°C constant baseplate temperature

RP0603ZZ-XXXXWN-2Q Dimensions:

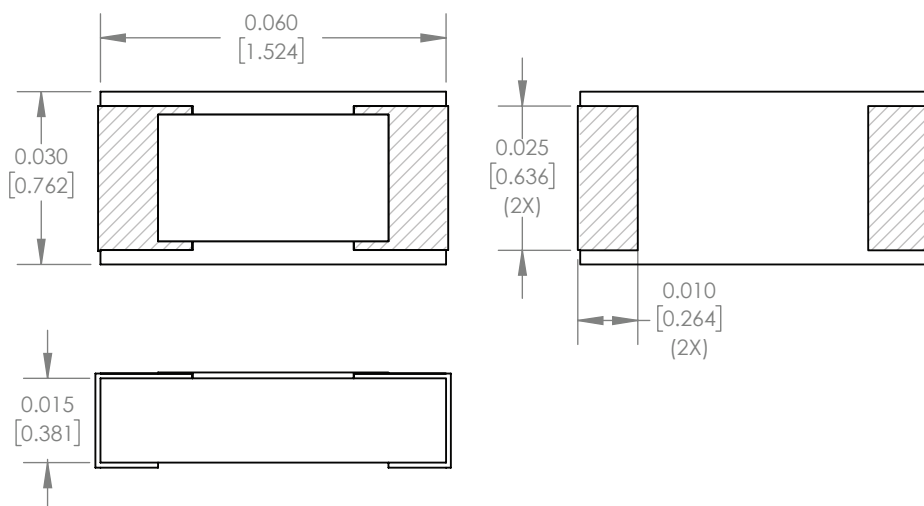

RP0603ZZ-XXXXWN-2Q Power Derating Curve

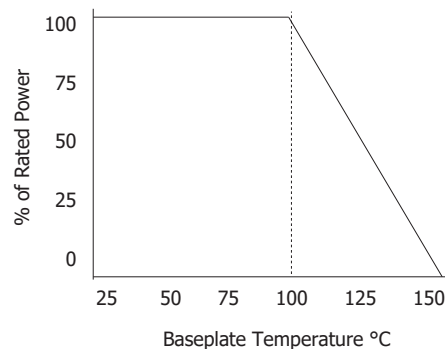

Dimensions in inches [mm]
 Tolerance is ± 0.005 [0.127]
 unless otherwise stated

Ordering Information:

Example Part Number: RP0603CT-50R0JN-2Q

RP	0603	ZZ	-	XXXX	W	N	-	2Q	UU
Prefix for Wraparound Resistor	Size 0603	Value Code Examples 10R0 - 10Ω 1000 - 100Ω 1001 - 1KΩ		Normal Inspection Contact factory for additional options	Tolerance F - 1% G - 2% J - 5%		Substrate 2Q - 0.015" AIN		Packaging Blank - Bulk TR - Tape and Reel WP - Waffle Pack
Terminal Metallization		RoHS	Magnetic	Solder	Epoxy	Wirebond			
BA - Palladium Silver		Yes	No	No	Yes	No			
BS - SnPb over Palladium Silver		No	No	Yes	No	No			
CT - 100% Matte Tin over Nickel over Silver		Yes	Yes	Yes	No	No			
CB - SnPb over Nickel over Silver		No	Yes	Yes	No	No			
GA - Gold		Yes	No	No	Yes	Yes			

Barry Industries reserves the right to change part number and/or process without notification.

RP0603ZZ-XXXXWN-2Q Reliability Specifications:

Parameter:	Test Condition:	Results:
Short Time Overload	Apply 1.1x Rated Power for 5 Seconds.	≤ 5.0% Resistance Shift
Rated Load Life	Apply 1/2 Power Under 40°C ±2°C 90 Minutes on/ 30 Minutes off. Repeat for 100 hours	≤ 5.0% Resistance Shift
Moisture Resistance	MIL-PRF-55342 para 4.8.9 95% RH, 25°C - 65°C	≤ 5.0% Resistance Shift
Resistance to Soldering Heat	MIL-STD-202 Method 210 and MIL-PRF-55342 Para 4.8.8.1	≤ 5.0% Resistance Shift
Solderability	MIL-PRF-55342 Para 4.8.12	>95% Covered
High Temperature Storage	125°C ±2°C for 500 Hours	1.) ≤ 5.0% Resistance Shift 2.) No Significant Abnormality (Visual)
Thermal Shock	-65°C to +150°C 30 Minutes Dwell, 5 Cycles	1.) ≤ 5.0% Resistance Shift 2.) No Significant Abnormality (Visual)

Barry Industries reserves the right to change part number and/or process without notification.